



## ANALYSIS OF SOIL WATER INFILTRATION IN DIFFERENT TYPES OF USE AND COVER USING A DOUBLE RING INFILTROMETER

### ANALYSIS OF WATER INFILTRATION IN SOIL UNDER DIFFERENT LAND USE AND COVER TYPES USING A DOUBLE RING INFILTROMETER

Renei Rocha de Carvalho – Master in Environmental Technology and Water Resources - UnB Karine

Marreiro Soares - Master in Water Resources Management and Regulation - UNEMAT Johny Dias

Marinho – Specialist in Environmental Management – FAPAN

Allisson Cordeiro Bessa de Oliveira - Master in Water Resources Management and Regulation – UNEMAT

Aguiel Messias de Lima – Doctor of Science: Ecology and Natural Resources – UFSCar.

#### SUMMARY

Infiltration is the process by which water enters the soil surface and is one of the main flows in its water balance and in its hydrological cycle. Knowledge of the infiltration rate of water in the soil is important for defining soil conservation methods, planning and dimensioning of irrigation and drainage systems. In this sense, the article presents the results of an analysis of the accumulated infiltration (IA) and infiltration rates (TI) of soil from four sample points collected in the *Campus* Colorado do Oeste of the Federal Institute of Education, Science and Technology of Rondônia. The data were obtained with the help of double-ring infiltrometers. The work was carried out in September 2018. The results obtained of TI – cm/h for each soil sampled were: agriculture - 14.2; Forest - 165.0; Pasture - 4.0; and Exposed Soil - 11.2.

**Keywords:** Infiltration Rate, *Campus* Colorado; Infiltrometer.

#### ABSTRACT

Infiltration is the process by which water enters the soil surface and is one of the main flows in the water balance and in the hydrological cycle of the soil. Knowledge of the velocity of infiltration of water in the soil is important to define soil conservation methods, planning and design of irrigation and drainage systems. In this sense, this study presents the results of an analysis of accumulated infiltration (IA) and soil infiltration rates (TI) of four sample points collected at Colorado do Oeste *Campus* of the Federal Institute of Education, Science and Technology of Rondônia. The data were obtained with the aid of double ring infiltrometers. The work was carried out in September, 2018. The results obtained from TI - cm/h for each sampled soil were: agriculture - 14.2; Forest 165.0; Pasture - 4.0; and Solo Exposed - 11.2.

**Keywords:** Infiltration rate; *Campus* Colorado; Infiltrometer.

## 1. INTRODUCTION

Water infiltration occurs through its process of entering the soil through the surface, traveling through its profiles. It is one of the main flows in the hydrological cycle and in the soil water balance (RAHMATI et al., 2018). This penetration decreases over time, depending on the wetting of the profile, degree of compaction, porosity, size and distribution of its particles and assumes a constant value, called basic infiltration rate (POTT; MARIA, 2003).

Water infiltration and its subsequent redistribution into the subsoil are two processes that influence several of its activities, including the availability of water and nutrients to plants, microbial activity, erosion rates, chemical weathering, and thermal and gas exchange between the soil and the atmosphere. (RAHMATI *et al.*, 2018; CAMPBELL, 1985).

Infiltration plays a definitive role in maintaining soil system functions and is a key process that controls several of the United Nations sustainability goals (KEESS-TRA *et al.*, 2016).

Forest areas have soils with high porosity and high moisture levels, due to the existing organic matter, thus becoming a cementing constituent that keeps the soils aggregated. Its decomposition favors microbial, insect and animal activity, which contributes to forming preferential paths, preserving the porosity for the movement of water in the soil (POTT; MARIA, 2003). Another factor that facilitates infiltration in these areas is the root system of plants, and with its

1

development creates preferential paths for the movement of water in the soil, increasing the infiltration rate. In addition to this factor, the presence of vegetation reduces the impact of raindrops, thus reducing surface runoff (CARVALHO and SILVA, 2006). The forest ecosystem plays a significant role in the conservation and improvement of water quality; forest soil is one of the main responsible for hydrological conservation (BIAO *et al.*, 2010).

In soils where agricultural and livestock activities are carried out, changes occur to their original characteristics, such as compaction caused by the movement of machinery and the trampling of animals, thus hindering the infiltration process and increasing surface runoff (YIMER *et al.*, 2008; CARVALHO and SILVA, 2006).

Exposed soils generally have low infiltration rates. Due to the absence of vegetation, raindrops, when they reach the soil surface, can promote compaction, reducing infiltration capacity. The intensity of this action varies according to the amount of vegetation cover, the kinetic energy of precipitation and the stability of soil aggregates (CARVALHO and SILVA, 2006).

Infiltration rate (IT) is the speed at which water enters the soil, usually measured by the depth in millimeters of the water layer that can enter the soil in one hour (POOJASHREE; BHAVYA, 2016). The infiltration rate of water in the soil is a determination that has been widely studied and there is still no general and well-established consensus on which is the best technique for its determination. Several field methods have been used to determine the IT of a soil such as: double-ring infiltrometer, rain simulator, tension infiltrometer, permeameter and/or pressure infiltrometer (ZWIRTESE *et al.*, 2013; POTT; MARIA, 2003), among them the double ring infiltrometer method can be highlighted, as it is simple and easy to perform (FAGUNDESE *et al.*, 2012).

This test method describes a procedure for measuring the rate of infiltration of water through soils on site using a double ring infiltrometer. The method used to specify how the data are collected and calculated in this standard is not directly related to the accuracy with which the data can be applied to other uses. This test method provides a direct measure of the infiltration rate (POO-JASHREE; BHAVYA, 2016). The selection of methods for determining the TI depends on the irrigation system to be used ZWIRTESE *et al.*, 2013).

Being an important hydrological parameter, soil infiltration rate can be used as an indicator of degradation and drought potential (WU *et al.*, 2016). Soil management is presented as being largely responsible for changes in IT (ZWIRTESE *et al.*, 2013). Determining soil quality and infiltration rates are important for understanding and preventing processes that occur in the soil, planning and dimensioning irrigation and drainage systems, which aim at conservation, optimization of human labor, economic development and reduction of the environmental impact generated in the region, in addition to promoting policies and strategies for its best use (RIQUELME *et al.*, 2012; YIMER *et al.*, 2008).

THE *Campus* Colorado do Oeste has a large area where several agricultural and livestock activities related to research are developed. These activities are closely linked to soil use and management. Therefore, it was decided to carry out a study with the objective of evaluating the accumulated infiltration and the water infiltration rate in different types of land use and cover in areas located at the Federal Institute of Education, Science and Technology of Rondônia. *Campus* Colorado of the West.

## 2. MATERIAL AND METHOD

The research was carried out at the Federal Institute of Rondônia *Campus* Colorado do Oeste on September 22, 2018. The Colorado do Oeste Campus has its headquarters located at BR 435, Km 63, rural area of the municipality, being a farm school with an area of 2,412.85 m<sup>2</sup>. *Campus* It is a farm school, which has around 1,200 students enrolled in 2 technical courses (Agriculture and Food) and 4 higher education courses.

2

(Agricultural Engineering, Animal Science, Biology and Environmental Management), and accommodation with capacity for 128 male and 80 female resident students. Figure 1 shows the study area used for soil water infiltration tests.

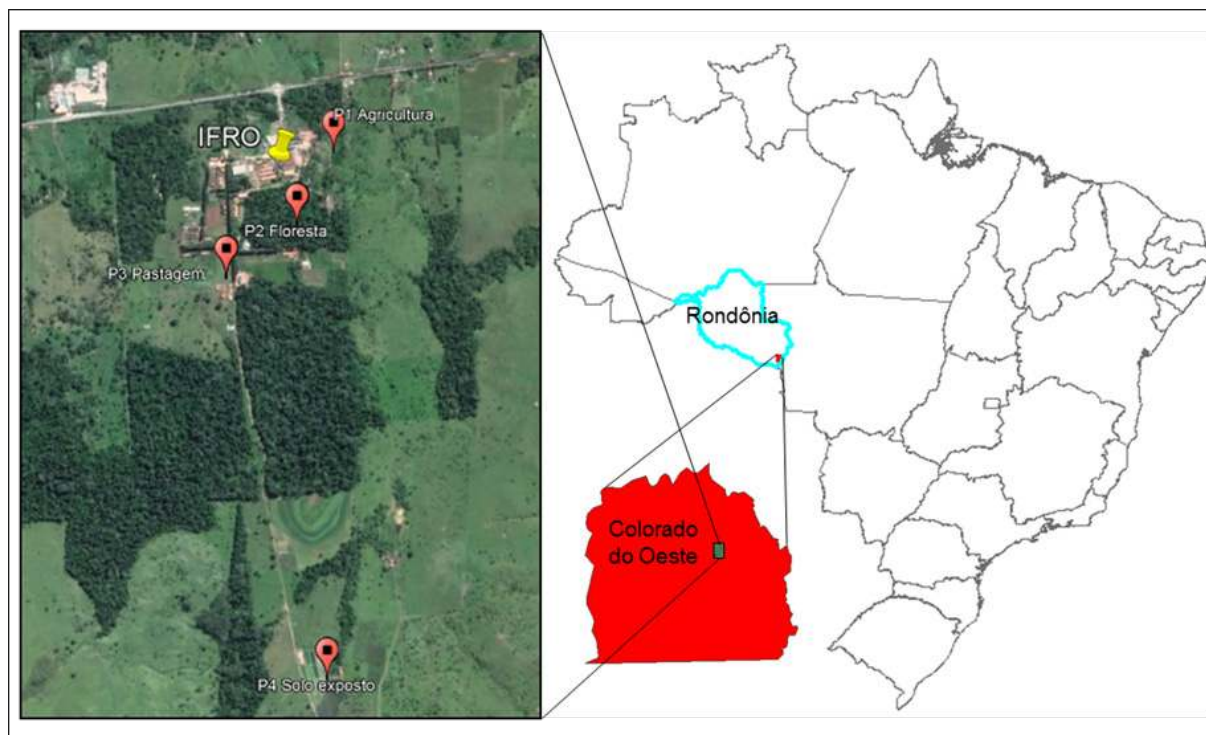

Figure 1. Location of the study area.

The studied area is located in the southern cone region of Rondônia. This region is characterized by highly fragmented native vegetation due to agriculture and livestock farming, its main economic activities. Soybean monoculture is the main agricultural crop in the state, with the southern region, which includes the municipalities of Cerejeiras, Corumbiara, Chupinguaia, Pimenteiras do Oeste, Cabixi and Colorado do Oeste, being the largest producer (PEREIRA; KAHIL, 2010).

Lisboa and Ferreira (2011), in their study on geoenvironmental zoning, classify the region in which the *Campus* Colorado do Oeste is considered moderately unstable because it has fertile soils and medium and wide interfluvial areas, which indicate that they can be used for conservation practices. It is a region drained by several intermittent streams. IFRO is included in this context. *Campus* Colorado do Oeste, which has a large area totaling 241 hectares. The *campus* It has some fragments of forest and its two largest ones total 69 hectares, surrounded in parts by pasture.

It was decided to analyze the infiltration of water into the soil in the IFRO/Colorado do Oeste area, since it is quite large and is home to a variety of activities, such as raising animals, raising fish and farming, as well as other activities related to research and extension on the Campus. With the development of these activities, the composition of the use and coverage of the soil in the area becomes quite diverse, which also characterizes diverse infiltration rates.

To assess the infiltration behavior of soil used for agriculture, forest soil, pasture soil and exposed soil in the Campus area, it was first necessary to manufacture a double-ring infiltrometer. The infiltrometer was manufactured in a facility that manufactures gutters and flashings for houses.

and, for this purpose, a 0.43 mm zinc plate was used. The dimension of the infiltrometer is described in Figure 2.

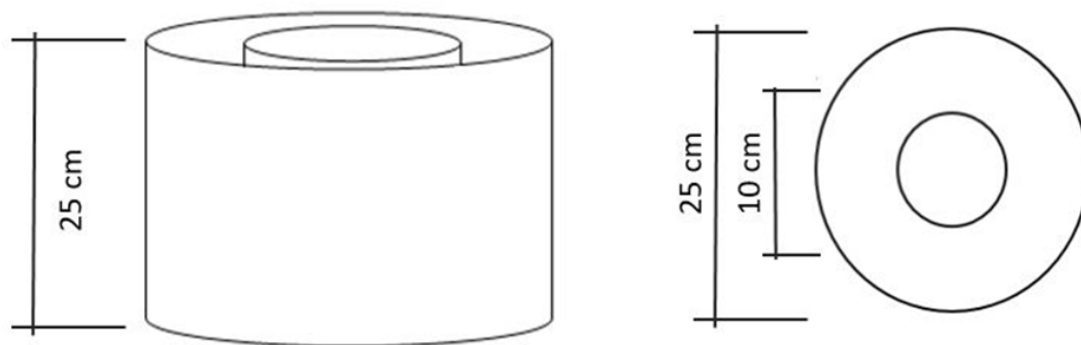

Figure 2. Concentric ring infiltrometer (Source: Melo DP).

The measurement is done in the inner cylinder; the outer cylinder is used only as a tool to ensure that the water from the inner cylinder flows downwards and not laterally. The soil surface in the inner cylinder is covered by a perforated metal plate which is used to dissipate the force of the applied water, to distribute the water evenly within the ring and to avoid disturbance of the soil surface (POOJASHREE; BHA-VYA, 2016).

Infiltration data collection was carried out at four different points located in the area of IFRO Campus Colorado do Oeste. The selection of collection points, since they are located in a large area, was aided by satellite imagery (Google Earth). By analyzing the image, the points in the areas of agriculture, forest, pasture and exposed soil were defined.

Infiltration rate measurements were performed using a double-ring infiltrometer. For each selected point, using a hammer, the inner ring was first driven into the ground approximately 5 cm deep, then the outer ring was driven in line with the central ring. Once this was done, the rings were filled simultaneously and a ruler was fixed in the center of the inner ring to measure the water level. After this, the water level was marked every 5 (five) minutes, using a stopwatch for a period of 30 (thirty) minutes. The accumulated infiltration (AI) and the infiltration rate (IT) were determined. by Equations 1 and 2, respectively.

		(1)
--	--	-----

Where:

IA = Accumulated Infiltration (cm);

$\Delta H_1$  = Previous difference (cm);

$\Delta H_2$  = Current difference (cm);

		(2)
--	--	-----

Where:

TI = Infiltration Rate (cm/h); t  
= time (min).

### 3. RESULTS AND DISCUSSION

In this study, the Accumulated Infiltration (AI) and the Infiltration Rate (IT) of water in the soil were analyzed in four different types of land use and cover: soil used for agriculture, forest soil, and pasture and exposed soil. The results of the soil water infiltration rate are presented in Table 1.

Table 1-Points, types of land use and cover and water infiltration rate into the soil.

Point	Coverage Type	Infiltration Rate (cm/h)
1	Agriculture	14.2
2	Forest	165.0
3	Pasture	4.0
4	Exposed Soil	11.2

According to Table 1, it can be observed that the forest soil presented the highest infiltration rate, 165 cm/h, followed by the soil used for agriculture, which was 14.2 cm/h. On the other hand, the pasture soil presented the lowest infiltration rate, 4.0 cm/h, followed by the exposed soil, which presented an IT of 11.2 cm/h. The results of the study of water infiltration rate in the soil conducted by Nunes et al. (2012) also showed high values for soil with vegetation cover, when compared to soil without vegetation cover, since, according to the authors, soils with vegetation cover tend to have a higher infiltration rate, due to factors such as the presence of channels formed by roots, the presence of organic matter, and microbiological activity. Soils with the presence of forests present high infiltration rates, while uncovered soils present low infiltration rates (SANTOS et al., 2017).

Regarding the measurement of the infiltration rate for the soil used for agriculture, it was observed that this area is used for the plantation of açai (*Euterpe oleracea*) for research purposes on the Campus. The second point analyzed was the forest soil, which presents a fragment of dense secondary rainforest. The third point corresponds to the pasture soil, used for raising cattle for research purposes and supplying the Campus cafeteria, which is used by students and staff for lunch and dinner. The fourth point concerns the exposed soil, which is located on the edge of one of the fish farming tanks used for research purposes and also for supplying the cafeteria. Figures 3a, 3b, 3c and 3d show the measurement points.

infiltration conditions in agricultural soil, forest soil, pasture soil and exposed soil, respectively.

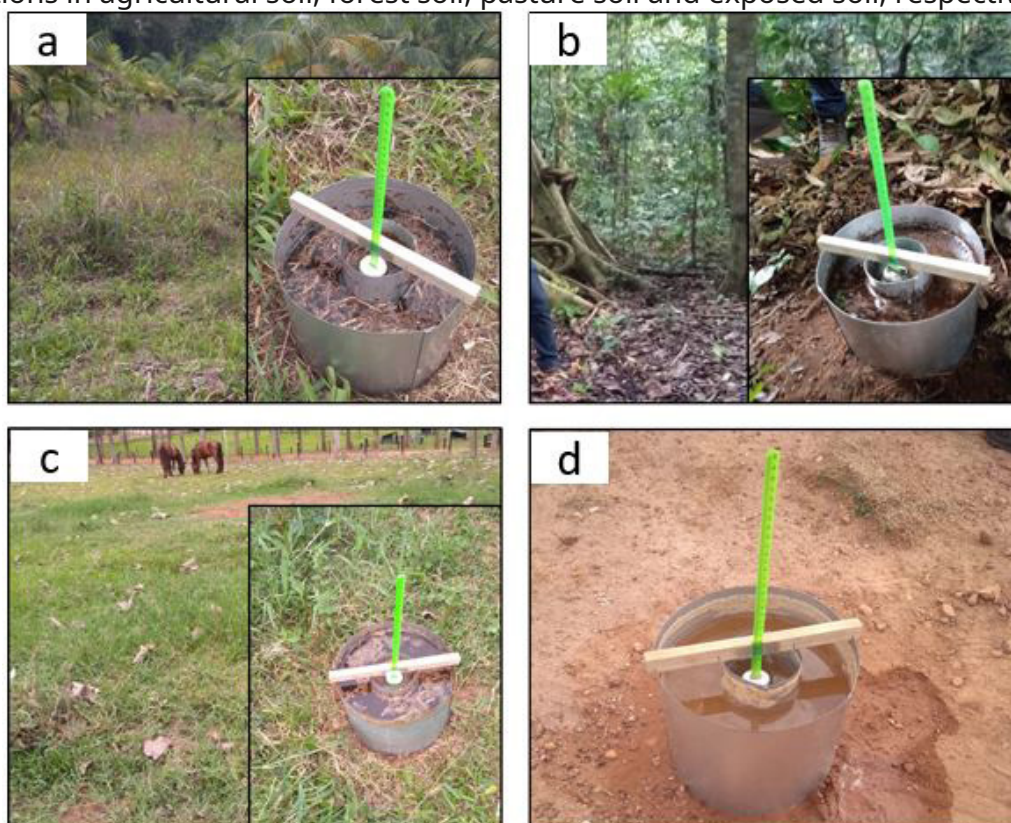

Figure 3. Infiltration: a) agricultural soil, b) forest soil, c) pasture soil and d) exposed soil.

Regarding the comparison of accumulated infiltration and infiltration rate, it is worth noting that it was not possible to graphically analyze the result obtained for the forest soil with the others, the water infiltration in this one was quite high, since in just six minutes the entire volume of stored water was infiltrated. The infiltration rate for the forest soil was 165 cm/h, a similar result was obtained by Costanaro *et al.*, (2009) in soil with advanced stage forest cover, which was 117.15 cm/h.

Figure 4a shows the comparison of accumulated infiltration between agricultural soil, pasture soil and exposed soil, where it can be observed that there was greater water infiltration in the agricultural soil (7.1 cm), since it is an açai crop, where its root system favors water infiltration into the soil. According to Oliveira (2002), the root system of the açai palm is of the fasciculated type, relatively dense, with roots of the adult plant of approximately 1 cm in diameter and extension that can reach 5 to 6 meters. On the other hand, the accumulated infiltration in the soil used for pasture was the lowest among the others, a fact that can be justified by the compaction of the soil by animals. The management of animals on pastures causes changes in the physical properties of the soil, and the pressures applied by the animals' trampling cause changes in the density and porosity of the soil, making water infiltration difficult (BERTOL *et al.*, 2000).

a) b)

Figure 4. Comparisons: a) accumulated infiltration and b) infiltration rate.

When comparing the water infiltration rate in the soil under different types of land use and cover (Figure 4b), it can be observed that in agricultural soil, the rate was high in the first 10 minutes (26.4 cm/h) and began to stabilize after 25 minutes (9.6 cm/h). The high infiltration rate in agricultural soil can be explained by the lack of machinery movement in the area, which can compact the soil. For pasture soil, which presented lower rates, there was not much variation, starting at 6 cm/h and stabilizing at 2.4 cm/h after 30 minutes.

#### 4. FINAL CONSIDERATIONS

According to the analyses carried out by the study, it was concluded that forest soil had higher accumulated infiltration (AI) and infiltration rate (IR) than agricultural soil, pasture soil and exposed soil, since soils with vegetation cover have a higher infiltration rate due to the presence of the plant root system, which allows for greater accumulation of water in the soil. On the other hand, soils without vegetation cover favor surface runoff. Pasture soil had the lowest accumulated infiltration and infiltration rate, because this type of soil cover is compacted by animal trampling, reducing soil pores, increasing density and hindering water infiltration into the soil.

Wu *et al.* (2016) and Santi *et al.* (2012) state that the use of only one or two parameters cannot comprehensively assess the soil infiltration capacity; more than two parameters are necessary for a more accurate definition. In view of this issue, the study opens up the possibility of other research that helps to better understand the characteristics of the soil in the region.

#### REFERENCES

- BERTOL, I.; ALMEIDA, JA; ALMEIDA, EX; KURTZ, C. Soil physical properties related to different levels of forage supply of dwarf elephant grass cv. Mott. **Brazilian Agricultural Research**, v.35, p.1047-1054, 2000.
- BIAO, Zhang *et al.* Water conservation of forest ecosystem in Beijing and its value. **Ecological Economics**, [s.l], v. 69, no. 7, p.1416-1426, May 2010. Elsevier BV. <http://dx.doi.org/10.1016/j.ecolecon.2008.09.004>.
- CAMPBELL, Gaylon S. SOIL PHYSICS WITH BASIC: Transport Models for Soil-Plant Systems. Amsterdam: **Elsevier**, 1985. 149 p.
- CARVALHO, DF; SILVA, LDB Hydrology. Rio de Janeiro: **Federal Rural University of Rio de Janeiro**, p.115, 2006.
- COSTANARO, TC; MAFFIA, VP; DIAS, HCT Water infiltration capacity in the soil in a fragment of Atlantic Forest in the municipality of Viçosa, MG. **Seminar on Water Resources of the Hydro-Basin**

- Paraíba do Sul graphic arts: Recovery of Degraded Areas, Environmental Services and Sustainability**, Taubaté, Brazil, p.149-156, 2009.
- FAGUNDES, EAA; KOETZ, M.; RUDEL, N.; SANTOS, TS; PORTO, R. Determination of infiltration and water infiltration rate by the ring infiltrometer method in cerrado soil in the municipality of Rondonópolis-MT. **Biosphere Encyclopedia**, Scientific Center Know - Goiânia, v.8, N.14; p. 369-378, 2012.
- KEESSTRA, Saskia D. et al. The significance of soils and soil science towards realization of the United Nations Sustainable Development Goals. **Soil**, [sl], v. 2, no. 2, p.111-128, 7 April. 2016. Copernicus GmbH. <http://dx.doi.org/10.5194/soil-2-111-2016>.
- LISBOA, Antônio de Melo; FERREIRA, Gilda Carneiro. Geoenvironmental zoning applied to the planning of environmental and territorial management of the municipality of Colorado d'Oeste, RO. **Geosciences**, São Paulo, v. 30, n. 2, p.219-235, March 25, 2011.
- NUNES, JAS; SILVEIRA, MHD; SILVA, TJA NUNES, PCM; CARVALHO, KS Infiltration rate by the concentric ring infiltrometer method in red latosol of cerrado. **Biosphere Encyclopedia**, v.8, n.15, p. 1685, 2012.
- OLIVEIRA, MSP; CARVALHO, JEU; NASCIMENTO, WMO; MULLER, CH Cultivation of açai palm for fruit production. **EMBRAPA**, 2002.
- PEREIRA, Mirlei Fachini Vicente; KAHIL, Samira Peduti. THE CORPORATE LOGIC OF LAND USE IN RONDÔNIA: SOYBEAN AGRIBUSINESS IN THE VILHENA REGION. **Field-territory: journal of agrarian geography**, [s. L.], v. 10, n. 5, p.288-311, 2010.
- POOJASHREE, BP; BHAVYA, P. Determination of Infiltration Rate of Soils using Double Ring Infiltrometer: Study of Soil Characteristics of Kundapura, Udipi Dist. **Ijsart**, [sl], v. 2, n. 10, p.26-28, 2016.
- POTT, CA; MARIA, IC de. Comparison of field methods for determining basic infiltration rate. **Brazilian Journal of Soil Science**, [sl], v. 27, no. 1, p.19-27, Feb. 2003.
- RAHMATI, Mehdi et al. Development and analysis of the Soil Water Infiltration Global database. **Earth System Science Data**, [sl], v. 10, no. 3, p.1237-1263, 2018.
- RIQUELME, Alexandra Maciel; LUZ, Larissa Helena Barbosa Pinheiro da; SILVA FILHO, Eliomar Pereira da. Water infiltration rate in dystrophic red-yellow latosol under different crops. **Brazilian Journal of Amazonian Sciences**, [sl], v. 1, no. 1, p.187-191, 2012.
- SANTI, Antônio Luis et al. SOIL WATER INFILTRATION, DETERMINED BY DIFFERENT METHODS, AS AN INDICATOR OF PRODUCTION POTENTIAL IN TWO OXIDISOLS MANAGED WITH PRECISION AGRICULTURE. **Interscience**, [sl], v. 37, n. 3, p.204-208, 2012.
- SANTOS, PMR; SILVA, APC; SILVA, JGG, SANTOS, MAL Evaluation of water infiltration in soil by the ring infiltrometer method. **INOVAGRI International Meeting**, 2017.
- WU, Gao-lin et al. Mixed artificial grasslands with more roots improved mine soil infiltration capacity. **Journal of Hydrology**, [sl], v. 535, p.54-60, 2016.
- YIMER, F. et al. Effects of different land use types on infiltration capacity in a catchment in the highlands of Ethiopia. **Soil Use and Management**, [sl], v. 24, no. 4, p.344-349, 2008.
- ZWIRTES, Anderson Luiz et al. Use of the Cornell infiltrometer and concentric rings to determine water infiltration in a Red Latosol. **Semina: Agricultural Sciences**, [sl], v. 34, n. 61, p.3489-3500, 2013.